



## Soft, pilot operated, balanced poppet relief valve

Capacity:  
200 gpm (760 L/min.)

Model:  
RPKT

### Product Description

Pilot-operated, soft relief cartridges limit maximum system pressure and also limit the rate of pressure rise. The valve opens and then ramps closed at a constant speed, independent of settings and flows. The adjust screw determines the maximum (relief) setting and the minimum (threshold) setting.

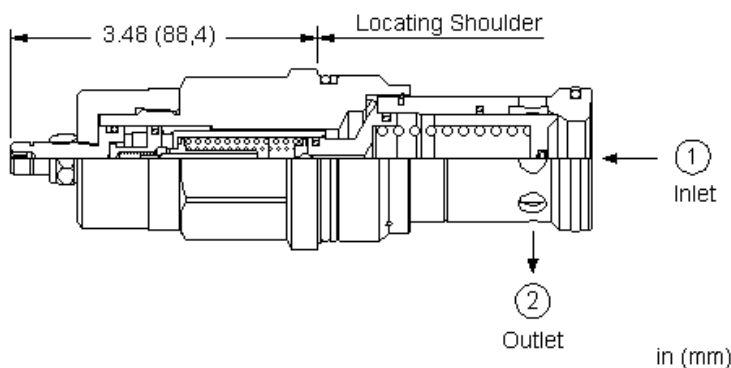
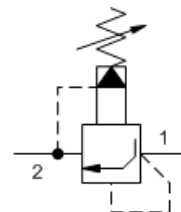

### Technical Features

- Will accept maximum pressure at port 2: suitable for use in cross port relief circuits.
- Not suitable for use in load holding applications.
- When pressure at the inlet (port 1) exceeds the threshold setting, the valve opens to tank (port 2). The pilot section moves forward at a steady rate, increasing the setting by compressing the pilot spring. Maximum setting is achieved when the pilot section reaches a mechanical stop.
- Valve provides protection for pumps and motors from pressure transients due to sudden load changes, especially variable displacement pumps, since the displacement mechanism is sometimes too slow to catch these pressure transients.
- Valve provides protection for hydrostatic drives by reducing the jerk caused by sudden reversals. The valve is suitable for cross-port applications.
- When used with a switching device, the valve can provide the ramp characteristic typically provided by proportional valves.
- Small power units can be started against a soft relief to provide longer pump life.
- All 2-port relief cartridges (except pilot reliefs) are physically and functionally interchangeable (same flow path, same cavity for a given frame size).
- Incorporates the Sun floating style construction to minimize the possibility of internal parts binding due to excessive installation torque and/or cavity/cartridge machining variations.

### Technical Data

	U.S. Units	Metric Units
Cavity		T-18A
Capacity	200 gpm	760 L/min.
Control Pilot Flow	10 - 25 in <sup>3</sup> /min.	0,16 - 0,41 L/min.
Factory Pressure Settings Established at	4 gpm	15 L/min.
Maximum Operating Pressure	5000 psi	350 bar
Pressure Ramp Up Time		500 ms
Response Time - Typical		2 ms

Series (from Cavity)	Series 4	
U.S. Patent #	6,039,070	
Adjustment - Number of Clockwise Turns to Increase Setting	4.5	
Valve Hex Size	1 5/8 in.	41,3 mm
Valve Installation Torque	350 - 375 lbf ft	475 - 500 Nm
Adjustment Screw Internal Hex Size	5/32 in.	4 mm
Adjustment Locknut/Cap Hex Size	9/16 in.	15 mm
Adjustment Nut Torque	80 - 90 lbf in.	9 - 10 Nm
Seal Kits - Cartridge	Buna: 990-318-007	
Seal Kits - Cartridge	Viton: 990-318-006	
Model Weight	2.99 lb.	1.36 kg.

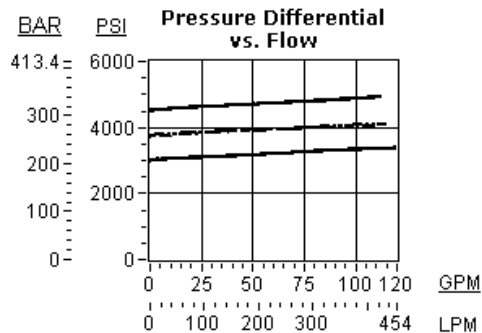
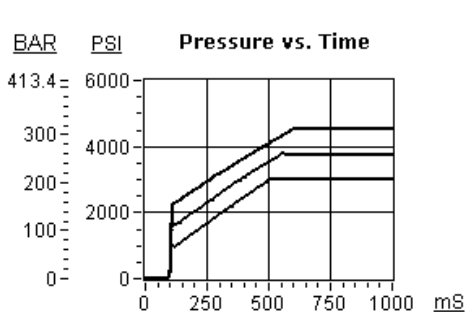

RPKT-LAN

Control	Adjustment Range	Seal Material
Standard Options	Standard Options	Standard Options
C* Tamper Resistant - Factory Set	A 2000 - 3000 psi (140 - 210 bar), 2000 psi (140 bar) Standard Setting	N Buna-N
L Standard Screw Adjustment	C 4500 - 6000 psi (315 - 420 bar), 4500 psi (315 bar) Standard Setting	V Viton
	W 3000 - 4500 psi (210 - 315 bar), 3000 psi (210 bar) Standard Setting	

\* Special Setting required, specify at time of order  
Customer specified setting stamped on hex.