



## Soft, ventable, pilot operated, balanced poppet relief valve

Capacity:  
120 gpm (480 L/min.)

Model:  
RVIT

### Product Description

Ventable, pilot-operated, soft relief cartridges limit maximum system pressure and also limit the rate of pressure rise. The valve opens and then ramps closed at a constant speed, independent of settings and flows. These 3 port valves include a vent port (port 3) that connects between the main piston and the pilot stage to provide for remote control by other pilot or 2-way valves. The adjust screw determines the maximum (relief) setting and the minimum (threshold) setting.

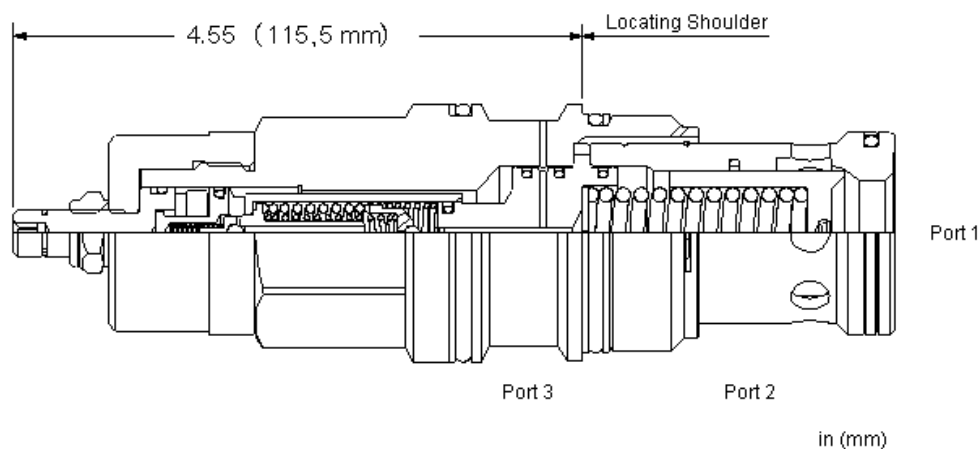
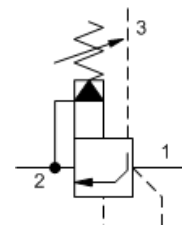

### Technical Features

- Because the modulating occurs inside the cartridge, these valves are immune to most of the problems associated with cavitation, namely noise and manifold erosion.
- Will accept maximum pressure at port 2: suitable for use in cross port relief circuits.
- A remote pilot relief on port 3 (vent) will control the valve below its own setting.
- Not suitable for use in load holding applications.
- When pressure at the inlet (port 1) exceeds the threshold setting, the valve opens to tank (port 2). The pilot section moves forward at a steady rate, increasing the setting by compressing the pilot spring. Maximum setting is achieved when the pilot section reaches a mechanical stop.
- Valve provides protection for hydrostatic drives by reducing the jerk caused by sudden reversals. The valve is suitable for cross-port applications.
- When used with a switching device, the valve can provide the ramp characteristic typically provided by proportional valves.
- Small power units can be started against a soft relief to provide longer pump life.
- The main stage orifice is protected against contamination.
- Incorporates the Sun floating style construction to minimize the possibility of internal parts binding due to excessive installation torque and/or cavity/cartridge machining variations.

### Technical Data

	U.S. Units	Metric Units
Cavity		T-19A
Capacity	120 gpm	480 L/min.
Control Pilot Flow	15 - 20 in <sup>3</sup> /min.	0,25 - 0,33 L/min.
Factory Pressure Settings Established at	4 gpm	15 L/min.
Maximum Operating Pressure	5000 psi	350 bar

Pressure Ramp Up Time	500 ms	
Response Time - Typical	2 ms	
Series (from Cavity)	Series 4	
Adjustment - Number of Clockwise Turns to Increase Setting	5	
Valve Hex Size	1 5/8 in.	41,3 mm
Valve Installation Torque	350 - 375 lbf ft	475 - 500 Nm
Adjustment Screw Internal Hex Size	5/32 in.	4 mm
Adjustment Locknut/Cap Hex Size	9/16 in.	15 mm
Adjustment Nut Torque	80 - 90 lbf in.	9 - 10 Nm
Seal Kits - Cartridge	Buna: 990-219-007	
Seal Kits - Cartridge	Viton: 990-219-006	
Model Weight	3.52 lb.	1.60 kg.

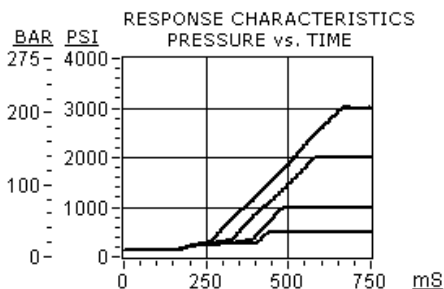
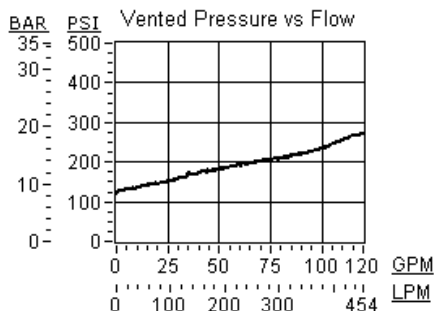
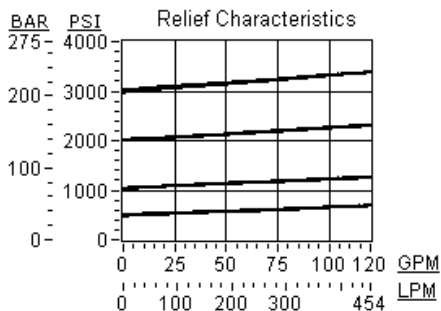

### RVIT-LAN

Control	Adjustment Range	Seal Material
Standard Options	Standard Options	Standard Options
C* Tamper Resistant - Factory Set	A 500 - 3000 psi (35 - 210 bar), 1000 psi (70 bar) Standard Setting	N Buna-N
K Handknob		V Viton
L Standard Screw Adjustment	C 1000 - 6000 psi (70 - 420 bar), 1000 psi (70 bar) Standard Setting	
	W 1000 - 4500 psi (70 - 315 bar), 1000 psi (70 bar) Standard Setting	

\* Special Setting required, specify at time of order  
 Customer specified setting stamped on hex.