



## Pilot operated, balanced poppet sequence main stage with integral T-8A control cavity

Functional Group:

Products : Cartridges : Electro-Proportional : Relief : 3-Port, Balanced Poppet, Relief

Capacity:  
30 gpm (120  
L/min.)

Model:  
RSFS8

### Product Description

This valve is a normally closed poppet element that incorporates an integral pilot control cavity. It is externally drained, and is a balanced poppet design. The pilot control cavity will accept any T-8A pressure control cartridge. When the pressure at the inlet (port 1) reaches the pilot control cartridge's setting, the poppet element starts to open to port 2, throttling flow to regulate the pressure. The pilot cartridge's setting determines the difference in pressure between the inlet (port 1) and the drain (port 3). These valves are insensitive to back pressure at port 2, up to the valve setting. They may be used to regulate pressure in place of 2-port relief valves if there is pressure in the return line.

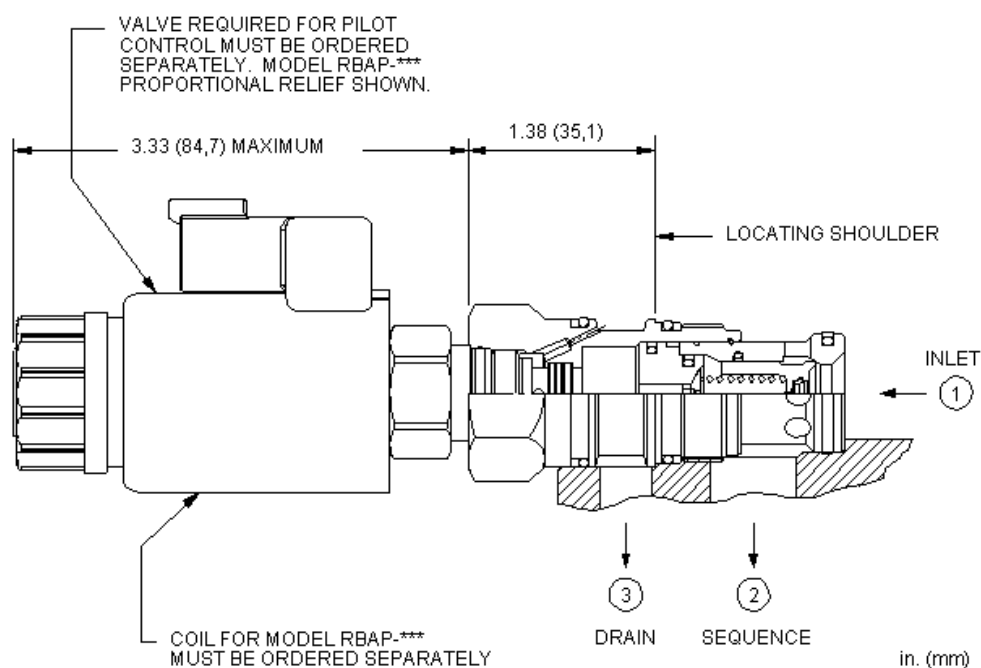
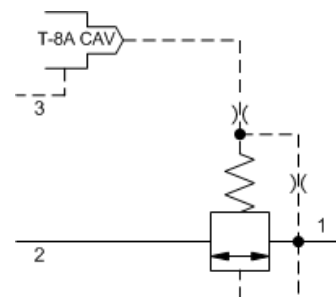

### Technical Features

- All 3 port sequence cartridges are physically and functionally interchangeable (i.e. same flow path, same cavity for a given frame size).
- Pilot flow continues to increase as the pressure at port 1 (inlet), relative to the pressure at port 3 (drain), rises above the valve setting.
- The main stage orifice is protected by a 150 micron stainless steel screen.
- Pressure at port 3 is directly additive to the valve setting at a 1:1 ratio and should not exceed 5000 psi (350 bar).
- The -8 control option allows the pilot control valve to be incorporated directly into the end of the relief cartridge via the T-8A cavity. These pilot control cartridges are sold separately and include solenoid operation, air pilot operation, and hydraulic pilot operation. See Pilot Control Cartridges.
- Because the modulating occurs inside the cartridge these valves are immune to most of the problems associated with cavitation, namely noise and manifold erosion.
- Will accept maximum pressure at port 2: suitable for use in cross port relief circuits.
- Incorporates the Sun floating style construction to minimize the possibility of internal parts binding due to excessive installation torque and/or cavity/cartridge machining variations.

- NOTE: With the -8 control option, the main stage valve should first be installed to the correct torque value. The T-8A pilot control valve should then be installed into the main stage valve to its required torque value.

## Technical Data

	U.S. Units	Metric Units
Cavity	T-2A	
Capacity	30 gpm	120 L/min.
Control Pilot Flow	10 - 15 in <sup>3</sup> /min.	0,16 - 0,25 L/min.
Main stage leakage at reseal	10 drops/min.	0,7 cc/min.
Maximum Operating Pressure	5000 psi	350 bar
Pilot Control Cavity	T-8A	
Pilot Control Valve Hex Size	7/8 in.	22,2 mm
Pilot Control Valve Installation Torque	20 - 25 lbf ft	27 - 33 Nm
Response Time - Typical	10 ms	
Series (from Cavity)	Series 2	
Valve Hex Size	1 1/8 in.	28,6 mm
Valve Installation Torque	45 - 50 lbf ft	60 - 70 Nm
Seal Kits - Cartridge	Buna: 990-402-007	
Seal Kits - Cartridge	Viton: 990-402-006	
Model Weight	0.43 lb.	0.20 kg.

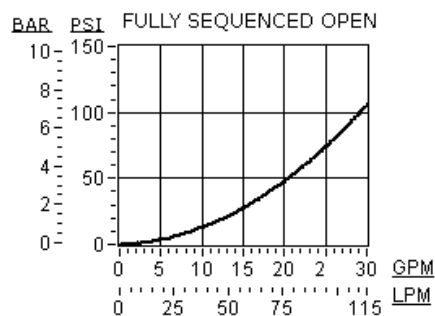
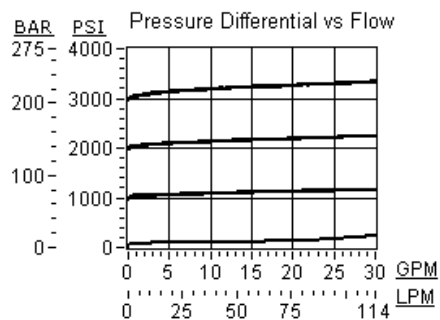

## RSFS-8WN

<b>Minimum Control Pressure</b>	<b>Seal Material</b>
Standard Options	Standard Options
B 50 psi (3,5 bar)	N Buna-N
W 100 psi (7 bar)	V Viton