



Fast-acting, pilot operated, balanced piston relief valve

Capacity:
200 gpm (760 L/min.)

Model:
RPKE

Product Description

Fast-acting, pilot-operated, balanced piston relief cartridges are normally closed, pressure-limiting valves used to protect hydraulics components from pressure transients. Fast opening and closing is gained at the expense of smoothness. When the pressure at the inlet (port 1) reaches the valve setting, the valve starts to open to tank (port 2), throttling flow to limit the pressure rise. These valves have low pressure rise vs. flow and are very fast.

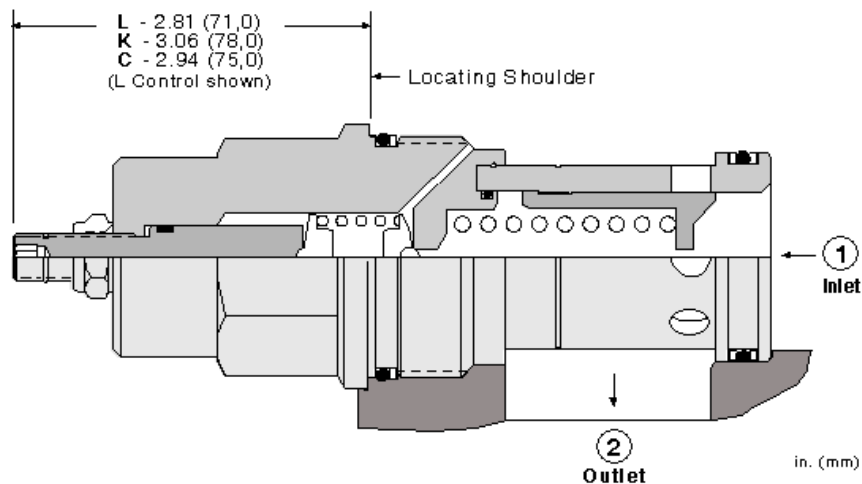
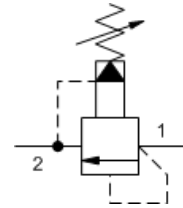

Technical Features

- Main stage orifice is protected by a 150 micron stainless steel screen.
- Not suitable for use in load holding applications due to spool leakage.
- Will accept maximum pressure at port 2: suitable for use in cross port relief circuits. If used in cross port relief circuits, consider spool leakage.
- Back pressure on the tank port (port 2) is directly additive to the valve setting at a 1:1 ratio.
- All 2-port relief cartridges (except pilot reliefs) are physically and functionally interchangeable (same flow path, same cavity for a given frame size).
- Incorporates the Sun floating style construction to minimize the possibility of internal parts binding due to excessive installation torque and/or cavity/cartridge machining variations.

Technical Data

	U.S. Units	Metric Units
Cavity	T-18A	
Capacity	200 gpm	760 L/min.
Factory Pressure Settings Established at	4 gpm	15 L/min.
Maximum Operating Pressure	5000 psi	350 bar
Maximum Valve Leakage at 110 SUS (24 cSt)	5 in ³ /min.@1000 psi	80 cc/min.@70 bar
Response Time - Typical	2 ms	
Series (from Cavity)	Series 4	
Adjustment - Number of Clockwise Turns to Increase Setting	5	
Valve Hex Size	1 5/8 in.	41,3 mm
Valve Installation Torque	350 - 375 lbf ft	475 - 500 Nm
Adjustment Screw Internal Hex Size	5/32 in.	4 mm

Adjustment Locknut/Cap Hex Size	9/16 in.	15 mm
Adjustment Nut Torque	80 - 90 lbf in.	9 - 10 Nm
Seal Kits - Cartridge	Buna: 990-018-007	
Seal Kits - Cartridge	Viton: 990-018-006	
Model Weight	2.59 lb.	1.17 kg.

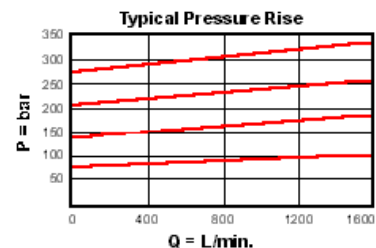
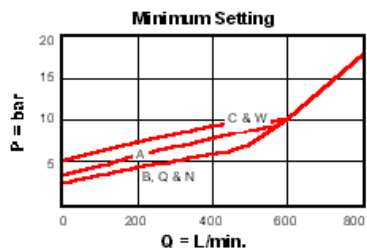
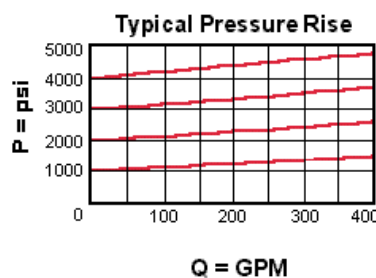
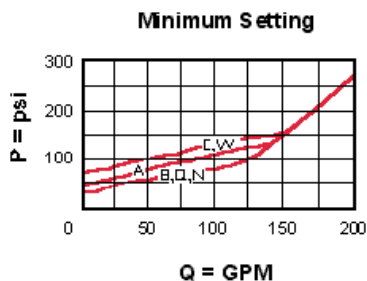

RPKE-LAN

Control	Adjustment Range	Seal Material	Material/Coating Modifier
Standard Options	Standard Options	Standard Options	Preferred Options
C* Tamper Resistant - Factory Set	A 100 - 3000 psi (7 - 210 bar), 1000 psi (70 bar) Standard Setting	N Buna-N	No modifier (standard material with no special coating)
K Handknob	B 50 - 1500 psi (3,5 - 105 bar), 1000 psi (70 bar) Standard Setting	V Viton	Special Options
L Standard Screw Adjustment	C 150 - 6000 psi (10,5 - 420 bar), 1000 psi (70 bar) Standard Setting		/AP Stainless Steel, Passivated
	D 25 - 800 psi (1,7 - 55 bar), 400 psi (28 bar) Standard Setting		Control: C
	E 25 - 400 psi (1,7 - 28 bar), 200 psi (14 bar) Standard Setting		Control: L
	W 150 - 4500 psi (10,5 - 315 bar), 1000 psi (70 bar) Standard Setting		

Our stainless product line is growing! If you are interested in a stainless option for this model which is not shown please contact Sun.

Additional Options

Control	Adjustment Range	Seal Material
	N 60 - 800 psi (4 - 55 bar), 400 psi (28 bar) Standard Setting	
	Q 60 - 400 psi (4 - 28 bar), 200 psi (14 bar) Standard Setting	

When the modifier is /AP, the control must be C or L

* Special Setting required, specify at time of order
Customer specified setting stamped on hex.